



Small Scale Solutions for your Farm

Sources of Water



Water Supply

An adequate supply of water is the main requirement for an irrigation system. Before you buy and install an irrigation system you must find a source of water and determine the rate (quantity) and quality of the water. Most important, your water rights must be known. In most locations there are laws, rules and regulations regarding the use of water. Be sure to obtain any necessary permits before proceeding with excavation or installation.

You must consider seasonal variations in the supply of water. A stream may look like a good source of water in spring, but will there be enough water when you need to irrigate in the middle of the summer? When selecting a water source, you must consider the level of risk you are willing to accept. Most high value crops need to have irrigation water available in 9 out of 10 years.

Water quality is important in evaluating water sources. A water test is needed to determine if the water is suitable for your crops.

In some cases in humid areas, brackish water can be used for irrigation. If the chief contaminant is sea water at a low concentration and the crop is salt tolerant and there is enough rainfall to leach the salts out of the root zone, then brackish water might be suitable.

Surface Water Sources

Stream flow is generally the cheapest source of water for irrigation. But it is also the least dependable. If your fields require more water than is available during dry weather, the water must be stored to ensure an adequate supply when needed.

There are many sources of water



A clean reliable water source is important for your irrigation system

Guidance documents lack the force and effect of law, unless expressly authorized by statute or incorporated into a contract. USDA may not cite, use, or rely on any guidance that is not available through their guidance portal, except to establish historical facts.



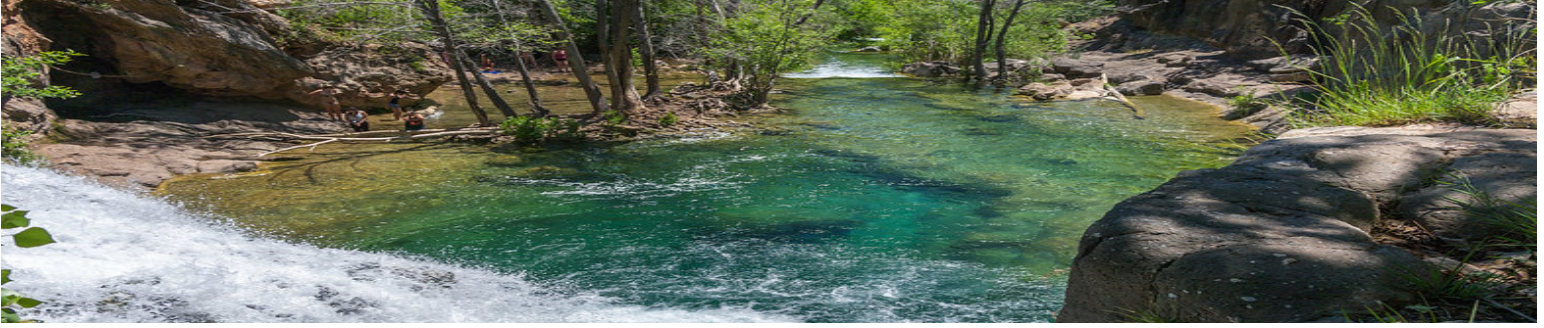

At some sites it may be possible to form a reservoir by constructing a dam across a gully or small valley that enters the stream. If the watershed above the dam is not large enough to furnish the required irrigation water, additional water can be pumped from the stream into the reservoir during the spring when flow is plentiful, thus supplying irrigation water later in the summer.

Rivers and Large Streams

Rivers can be reliable sources of irrigation water. In the Eastern states where water rights follow the riparian doctrine, water is available only to farms touching the stream. Natural lakes are a good source of irrigation water, but often withdrawal of water for irrigation is restricted. Unless a lake is large, or a farmer's land surrounds the lake, it may not be a dependable supply of water.

Farm Ponds

Farm ponds can be used for irrigation water. You may already have a farm pond, or you may be considering building one. NRCS can help you estimate the amount of water available for irrigation during the summer months. It is the total pond capacity minus the water lost through evaporation and seepage in addition to the storage lost to sediments.

Subsurface Water Sources

Most irrigation water from subsurface sources is supplied by wells although springs and dugout ponds may work.

A well consists of a hole, with or without a supporting casing extending down into a water-bearing formation. Wells are dug, driven or drilled depending on the soils, rock and the depth to the water table. Wells usually require a permit.



Farm ponds can be reliable sources of water for irrigation.



Typical drip irrigation system

Guidance documents lack the force and effect of law, unless expressly authorized by statute or incorporated into a contract. USDA may not cite, use, or rely on any guidance that is not available through their guidance portal, except to establish historical facts.





Natural springs near a crop field can be used as a source for irrigation water if the flow is adequate during the summer. Usually, a storage basin will be needed with a spring. The dependability of a spring is difficult to estimate unless you have watched it over many seasons. The capacity of springs can often be improved by excavating, cleaning, and providing collection and storage facilities. Caution must be taken to avoid draining wetlands when developing a spring.

Other Sources of Water

City water can be used for irrigation, although it is usually too expensive for large fields. For small areas of high value crops, using city water may be less than the cost of installing and operating pumps for an irrigation system. City water is perfect for drip irrigation systems since most of the impurities have already been removed. Most operators of city water systems require special back-flow prevention devices to prevent contamination of the water system.

Transporting water using a tank trailer or a truck mounted water tank may be a low-cost solution to water supply when a field is not close enough for direct irrigation from the water source and the amount of water needed is relatively small. This is especially true in the case of drip irrigation systems which require smaller amounts of water at low pressure.

You may be able to irrigate directly from the tank without a pump. You can fill the tank overnight from your household well, a spring, or pump it full from a stream or pond, then take it to your field and leave it there to run the drip system.

Rain barrels can be an inexpensive way to collect water for irrigation. Since the amount of water available is small and dependability is low, it is best suited for a small garden next to the house.

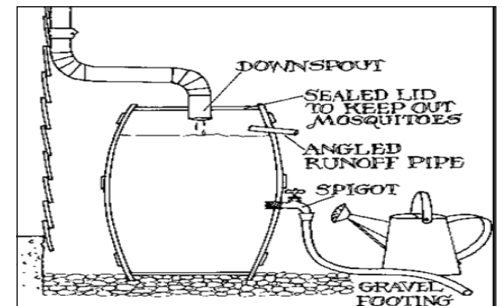

Rain barrel



Contact a specialist from NRCS for more assistance

Guidance documents lack the force and effect of law, unless expressly authorized by statute or incorporated into a contract. USDA may not cite, use, or rely on any guidance that is not available through their guidance portal, except to establish historical facts.





Technical and Financial Help Is Available

Whether you measure your farm in terms of feet or acres, your local Natural Resources Conservation Service (NRCS) office has experienced conservationists that can help you develop a Conservation Plan to conserve, maintain, and restore the natural resources on your land and improve the long-term health of your operation.

There is no charge for our assistance. Simply contact your local office to set up an appointment. You may also be eligible to receive financial assistance. Your NRCS office will explain any programs that are available so you can make the best decision for your operation. All NRCS programs and services are voluntary.

For More Information

Visit the [Natural Resources Conservation Service](#) or visit farmers.gov/service-locator to find your local NRCS office. You can also check with your local USDA Service Center, then make an appointment to determine next steps for your conservation goals.

In accordance with Federal civil rights law and U.S. Department of Agriculture (USDA) civil rights regulations and policies, the USDA, its Agencies, offices, and employees, and institutions participating in or administering USDA programs are prohibited from discriminating based on race, color, national origin, religion, sex, gender identity (including gender expression), sexual orientation, disability, age, marital status, family/parental status, income derived from a public assistance program, political beliefs, or reprisal or retaliation for prior civil rights activity, in any program or activity conducted or funded by USDA (not all bases apply to all programs). Remedies and complaint filing deadlines vary by program or incident.

Persons with disabilities who require alternative means of communication for program information (e.g., Braille, large print, audiotape, American Sign Language, etc.) should contact the responsible Agency or USDA's TARGET Center at (202) 720-2600 (voice and TTY) or contact USDA through the Federal Relay Service at (800) 877-8339. Additionally, program information may be made available in languages other than English.

To file a program discrimination complaint, complete the USDA Program Discrimination Complaint Form, AD-3027, found online at [How to File a Program Discrimination Complaint](#) and at any USDA office or write a letter addressed to USDA and provide in the letter all of the information requested in the form. To request a copy of the complaint form, call (866) 632-9992. Submit your completed form or letter to USDA by: (1) mail: U.S. Department of Agriculture, Office of the Assistant Secretary for Civil Rights, 1400 Independence Avenue, SW, Washington, D.C. 20250-9410; (2) fax: (202) 690-7442; or (3) email: program.intake@usda.gov.



NRCS conservationist assisting small scale farmer with developing a customized conservation plan.

Guidance documents lack the force and effect of law, unless expressly authorized by statute or incorporated into a contract. USDA may not cite, use, or rely on any guidance that is not available through their guidance portal, except to establish historical facts.

